

DENALI™

HMT.07.10500

SPLIT HORN MOUNT BMW

K1600GT 2011 - PRESENT
K1600GTL 2011 - PRESENT

Thank you for choosing DENALI

We know you would rather be riding your bike than wrenching on it, so we go the extra mile to make sure our instructions are clear and as easy to understand as possible. If you have any questions, comments, or suggestions don't hesitate to give our gear experts a call at 855.255.5550 or visit DenaliElectronics.com/instructions.

Please Read Before Installing

DENALI products should always be installed by a qualified motorcycle technician. If you are unsure of your ability to properly install a product, please have the product installed by your local motorcycle dealer. DENALI takes no responsibility for damages caused by improper installation. **Caution:** When installing electronics it is extremely important to pay close attention to how wires are routed, especially when mounting products to the front fender, front forks, or fairing of your motorcycle. Always be sure to turn the handlebars fully left, fully right, and fully compress the suspension to ensure the wires will not bind and have enough slack for your motorcycle to operate properly.

Installation Tips

We strongly recommend using medium strength liquid thread locker on all screws, nuts, and bolts. It is also important to ensure that all hardware is tightened to the proper torque specifications as listed in your owner's manual. For included accessory hardware please refer to the default torque specifications provided below. Inspect all hardware after the first 30 miles to ensure proper torque specifications are maintained.

Bolt Size	in-lbs	ft-lbs	Nm
M3	10.0 in-lbs	-	1.0 Nm
M4	23.0 in-lbs	-	2.5 Nm
M5	44.5 in-lbs	3.5 ft-lbs	5.0 Nm
M6	78.0 in-lbs	6.5 ft-lbs	9.0 Nm
M8	-	13.5 ft-lbs	18.0 Nm
M10	-	30.0 ft-lbs	41.0 Nm
M12	-	52.0 ft-lbs	71.0 Nm

Hardware Sizing Guide

Not sure what size bolt you have? Use this ruler to measure screws, bolts, spacers, etc. Remember, the length of a screw or bolt is measured from the start of the "mounting surface" to the end of the screw, so only include the screw head when measuring countersunk screws.

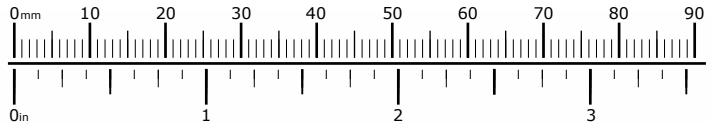

FIGURE 1

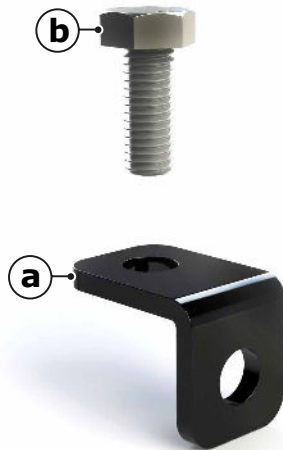

Illustration not to scale

Kit Contents

- (a) Bracket.....Qty 1
- (b) M8x20 DIN 933.....Qty 1

Tools Required

- 13mm Wrench
- T-25 Torx
- T-50 Torx

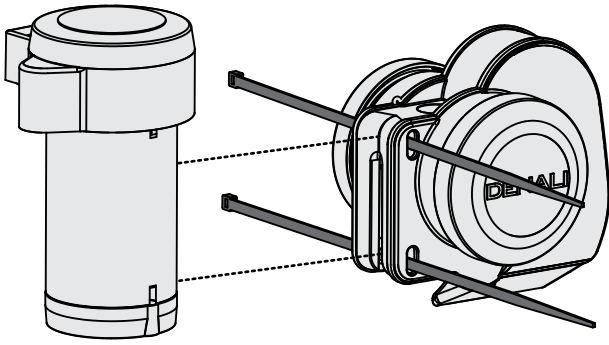
FIGURE 2

Assembling The Horn

Step One: Use the zip ties included with the Split Horn Kit to mount the trumpet to the compressor in the orientation shown above.

Note: Do not fully tighten the zip ties at this time, some final adjustments will be made once the horn is mounted to the bike.

Step Two: Use the rubber hose included with the Split Horn Kit to attach the trumpet to the compressor.

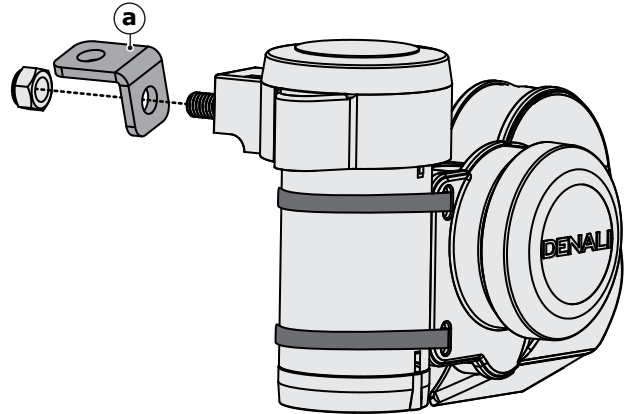
FIGURE 3

Mounting The Bracket

Step Three: Use the hardware included with the Split Horn Kit to attach the assembled horn the mounting bracket (a)

Note: Do not fully tighten the nut at this time. The bracket will be mounted on a slight angle. The final adjustment to this angle will be made when installing the horn to the bike.

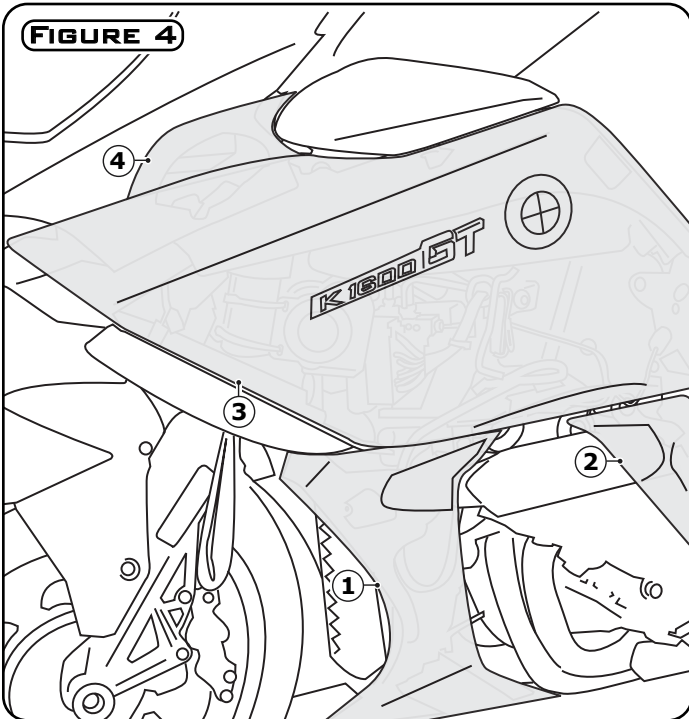
FIGURE 4

Accessing The Horn Mounting Point

Step Four: There are four panels that need to be removed in order to gain access to the horn mounting point. Start with the lowest panel (1) and work your way to the top of the bike (1-4) until all panels have been removed.

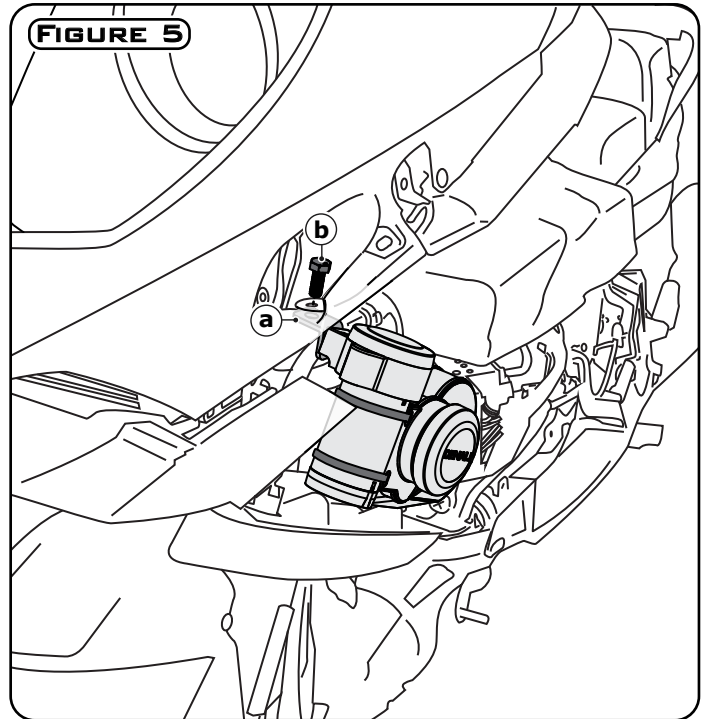
FIGURE 5

Installing The Horn

Step Five: Begin by removing the OEM horn and bracket from the bike. This mounting point will be re-used to mount the DENALI Horn. You will also re-use the clip nut attached to the OEM bracket.

Step Six: Before installing the horn, determine the angle that bracket (a) needs to be mounted the horn. Once determined you may fully tighten the nut.

Step Seven: Slide the OEM clip not onto the

end of the bracket (a), then use the M8x20 bolt (b) to attach the bracket (a) to the OEM horn mounting point.

Step Eight: Use the rubber hose included with the Split Horn Kit to attach the trumpet to the compressor. Once the hose has been installed you may fully tighten the zip ties attaching the trumpet the compressor.