



DRL LED Daytime Running Light

DNL.DRL.002 - White
DNL.DRL.004 - Amber

Thank you for choosing DENALI

We know you would rather be riding your bike than wrenching on it, so we go the extra mile to make sure our instructions are clear and as easy to understand as possible. If you have any questions, comments, or suggestions don't hesitate to give our gear experts a call at 401.360.2550 or visit WWW.DENALIELECTRONICS.COM

Please Read Before Installing

DENALI products should always be installed by a qualified motorcycle technician. If you are unsure of your ability to properly install a product, please have the product installed by your local motorcycle dealer. DENALI takes no responsibility for damages caused by improper installation. **Caution:** When installing electronics is it extremely important to pay close attention to how wires are routed, especially when mounting products to the front fender, front forks, or fairing of your motorcycle. Always be sure to turn the handlebars fully left, fully right, and fully compress the suspension to ensure the wires will not bind and have enough slack for your motorcycle to operate properly.

Installation Tips

We strongly recommend using medium strength liquid thread locker on all screws, nuts, and bolts. It is also important to ensure that all hardware is tightened to the proper torque specifications as listed in your owner's manual. For included accessory hardware please refer to the default torque specifications provided below. Inspect all hardware after the first 30 miles to ensure proper torque specifications are maintained.

Bolt Size	in-lbs	ft-lbs	Nm
M3	10.0 in-lbs	-	1.0 Nm
M4	23.0 in-lbs	-	2.5 Nm
M5	44.5 in-lbs	3.5 ft-lbs	5.0 Nm
M6	78.0 in-lbs	6.5 ft-lbs	9.0 Nm
M8	-	13.5 ft-lbs	18.0 Nm
M10	-	30.0 ft-lbs	41.0 Nm
M12	-	52.0 ft-lbs	71.0 Nm

Hardware Sizing Guide

Not sure what size bolt you have? Use this ruler to measure screws, bolts, spacers, etc. Remember, the length of a screw or bolt is measured from the start of the "mounting surface" to the end of the screw, so only include the screw head when measuring countersunk screws.

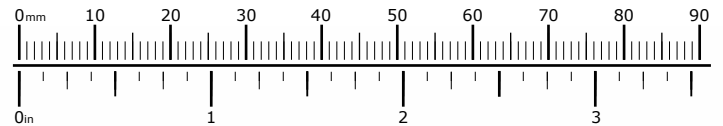

Whats In The Box?

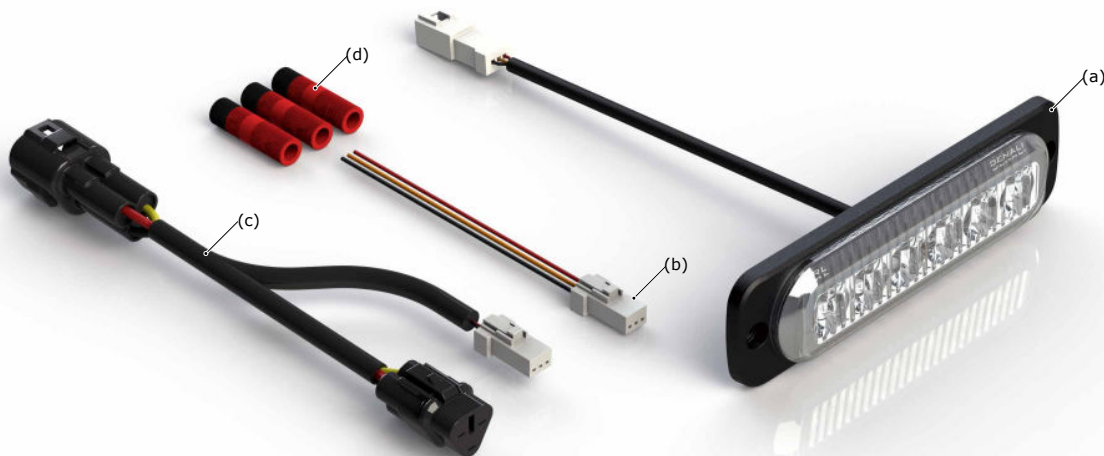

Kit Contents

- (a) DRL LED Light Pod.....Qty 1
- (b) Wiring Pigtail.....Qty 1
- (c) DENALI Harness Wiring Adapter.....Qty 1
- (d) Posi-Tap.....Qty 3

Tools Required

Voltmeter/Multimeter

1. Wiring To Vehicle Harness (Dual Intensity)

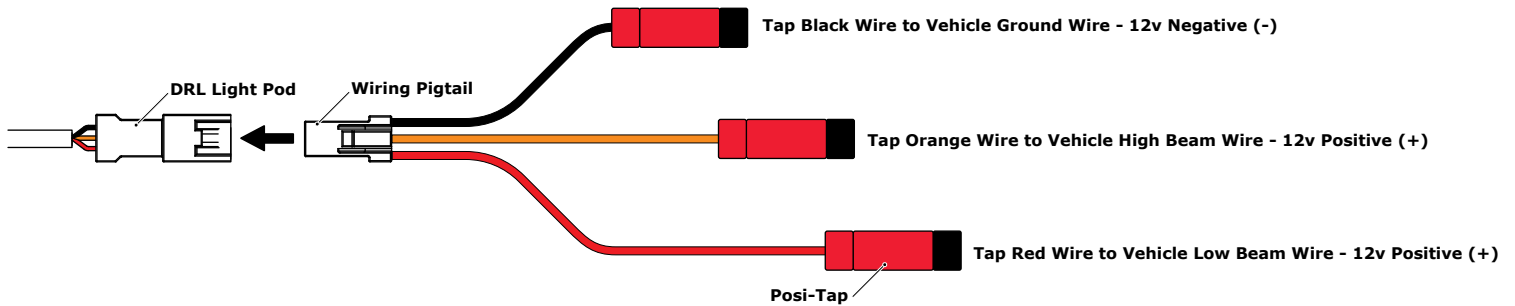

1.1 - Identifying Vehicle Wires

Complete with an integrated dual intensity circuit, the DRL Light Pod can be wired to run at full intensity, half intensity or automatically switch between the two with your vehicle's original high beam switch.

For dual intensity wiring, continue with *Section 1*, for single intensity wiring skip ahead to *Section 2*. For wiring to the CANsmart Controller or 2.0 Premium Wiring Harness continue to *Section 3*.

Step One: Route the cable from the DRL Light Pod (a) into the motorcycle to the area the factory head light connector is located.

Step Two: Identify the High Beam Wire, Low Beam Wire as well as the Ground Wire. Use a voltmeter or multimeter to assist in identifying the correct wires.

1.2 - Wiring The Pigtail

Step One: Use Posi-Tap connectors (d) to wire the Pigtail (b) to the wires identified in *Step Two* of *Section 1.1*.

- Tap the Red Wire to Vehicle Low Beam Wire
- Tap the Orange Wire to Vehicle High Beam Wire
- Tap the Black Wire to Vehicle Ground Wire

Step Two: Plug the Pigtail (b) into the connector of the DRL Light Pod (a).

2. Wiring To Vehicle Harness (Single Intensity)

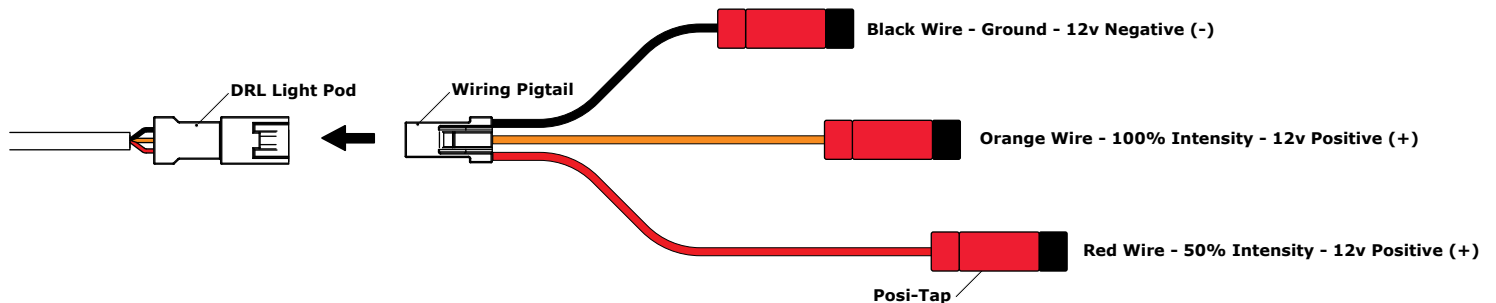

2.1 - Identifying Switched Power

This wiring option will power the lights with a single intensity level. To run the light at 100% intensity use the Orange Wire to tap switched power. To run the light at 50% intensity use the Red Wire to tap switched power.

Step One: Route the cable from the DRL Light Pod (a) into motorcycle.

Step Two: Two examples of possible switched power sources are the low beam and tail light, however there are many other possible sources in most vehicles. The simplest way to identify switched power is to use a test light to probe connectors/wires while cycling the ignition. A clean switched power source will only be live when the ignition is cycled "ON", it should lose power when the ignition is cycled "OFF".

2.2 - Wiring The Pigtail

Step One: Once a proper switched power source has been identified use the Posi-Tap (d) to tap the Red or Orange wire into the identified switched power source.

Step Two: Use a Posi-Tap (d) to tap the Black wire into one of the vehicles ground wires.

Step Two: Plug the Pigtail (b) into the connector of the DRL Light Pod (a).

3. Wiring To DENALI 2.0 Harness or CANsmart Controller

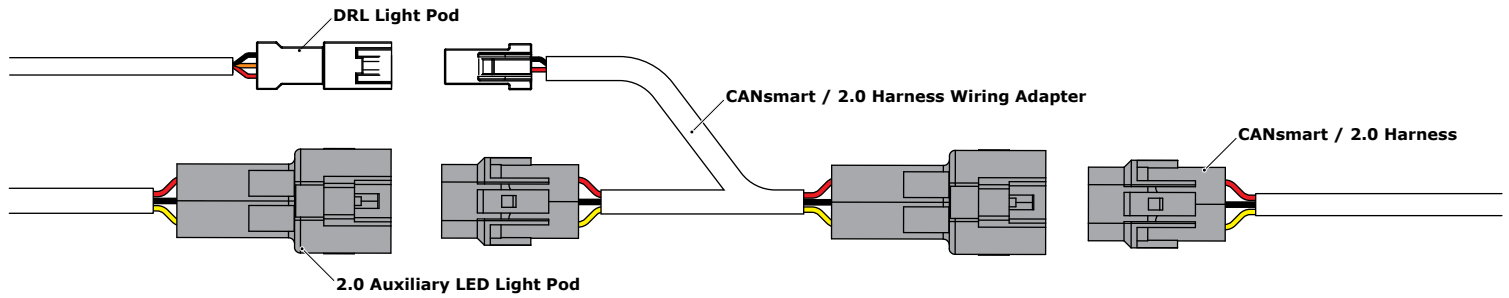

3.1 - Wiring DRL to 2.0 Harness

Use this wiring adapter to easily connect a set of DRLs to a DENALI Auxiliary Light Harness or CANsmart Controller. The pass through design allows the DRL Lights to be added to the light circuit in addition to the Auxiliary LED Lights.

Wiring DRLs To A Circuit WITH Existing Auxiliary LED Lights

Step One: Unplug the Auxiliary LED Light Pod from your CANsmart Controller or 2.0 Wiring Harness.

Step Two: Plug the Wiring Adapter (c) into the connector the light pod was removed from.

Step Three: Plug the Auxiliary LED Light Pod into the Wiring Adapter (c).

Step Four: Plug the DRL Light Pod (a) into the Wiring Adapter (c).

3.1 - Wiring Continued

Wiring DRLs To A Circuit WITHOUT Existing Auxiliary LED Lights

Step One: Plug the Wiring Adapter (c) into the light circuit connector of your CANsmart Controller or 2.0 Wiring Harness.

Step Two: Plug the DRL Light Pod (a) into the Wiring Adapter (c).